

## BENCH PANEL 02-07-5014

Parts List		
DESCRIPTION	QTY	PART NUMBER
BENCH PANEL	1	02-07-0015
PANEL CLAMP	4	02-07-0040
<b>HARDWARE COMPLETE</b>	1	33-12-0031
M8 x 30mm (1 3/16") BHCS BOLT	4	33-11-0104*
M8 LOCKWASHER	4	33-11-0301*
M8 x 25mm (1") BHCS BOLT	8	33-11-0103*
M8 LOCK NUT	8	33-11-0500*
CLAMP RIVET	4	33-11-0700*

*Unless Otherwise Specified, All Units of Measure are Each  
Items listed below Hardware Complete line are included with Hardware Complete Number*

**Warning: During Installation, Hardware And Small Parts Are Choking Hazards For Young Children. Store Unused Parts Appropriately Until Assembly Is Completed. Once Assembly Is Completed, Remove Any Unused Parts From The Play Environment And Dispose/Save Them In A Secure Location. Any bolt end protruding more than two full threads beyond the face of the nut causes risk of clothing entanglement.**

**Promptly cut-off flush, file smooth, and treat to prevent corrosion.**

**Note: Peen Tee-Nuts and Flatwashers to match radius of pipe after assembly is complete.**

**Note: Loctite (supplied by others) should be used on any non-patch hardware.**

### INSTALLATION INSTRUCTIONS:

**IMPORTANT: DETERMINE WHICH MOUNTING OPTION YOU ARE USING; SURFACE MOUNT, ONGROUND, OR IN-GROUND.**

1. Choose the appropriate Uprights to receive Bench Panel.
2. Attach Panel Clamps to Bench Panel using M8 x 30mm B.H.C.S. Bolt and M8 Lock Washer. See Detail 038.
3. Attach Panel Clamps to Upright using M8 x 25mm B.H.C.S. Bolt and M8 Lock Nut. See Detail 025. (Do not install Clamp Rivet until entire unit is assembled.)

**IMPORTANT: TOP OF BENCH MUST BE AT LEAST 9-1/2" (241mm) FROM BOTTOM OF DECK TO ELIMINATE POSSIBILITY OF HEAD ENTRAPMENT.**

4. Plumb and level entire assembly before tightening all fasteners. NOTE: Apply Loctite to threads of Bolt to prevent from loosening.

### MAINTENANCE PROCEDURE:

Periodically check hardware for tightness, and tighten as necessary. Always check all parts for breakage or wear, and immediately put equipment out of service until any faulty parts found are repaired or replaced. Also Check all metal parts for rust, paint loss and touch-up if necessary with paint. Check for welded areas and verify integrity. Check periodically resilient surfacing for appropriate depth and remove extraneous materials that could cause injury, infection, or disease. Maintain detailed installation, inspection, maintenance, and repair records for each public-use playground equipment.

## BENCH PANEL 02-07-5014

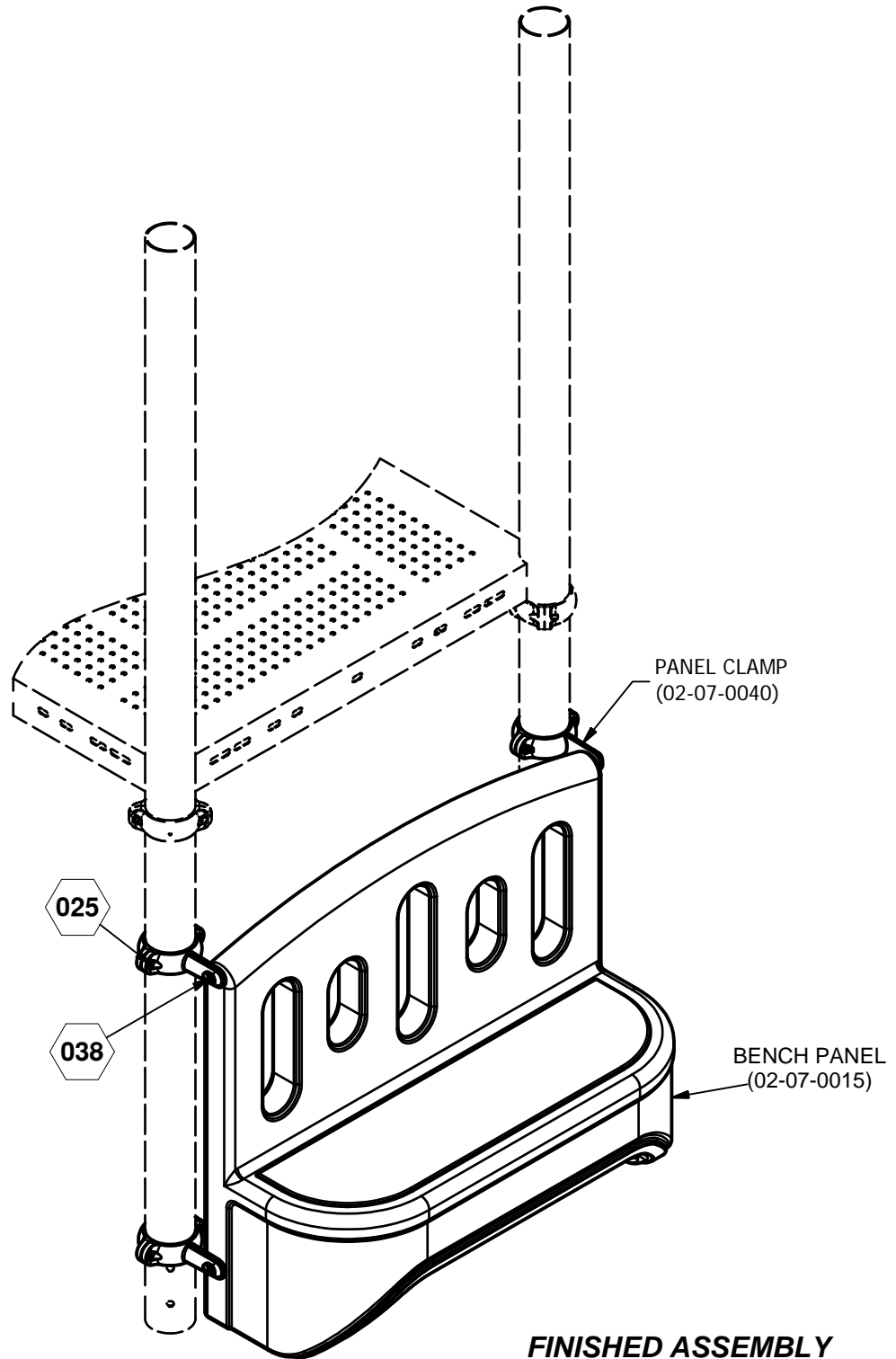

COMPONENTS SHOWN IN  
HIDDEN LINES ARE SOLD SEPARATELY

### FINISHED ASSEMBLY

 = INSTALLATION DETAIL

Issued/Revised: 04/23/13

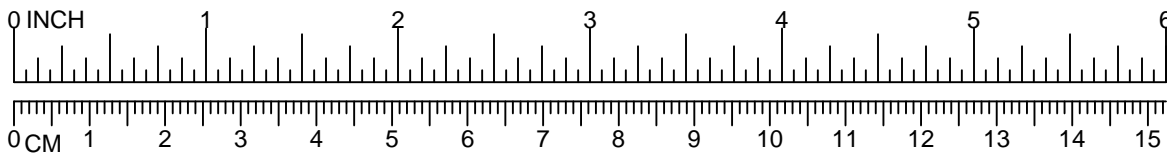

## BENCH PANEL 02-07-5014

