

UPLAY TODAY™

P L A Y S Y S T E M S

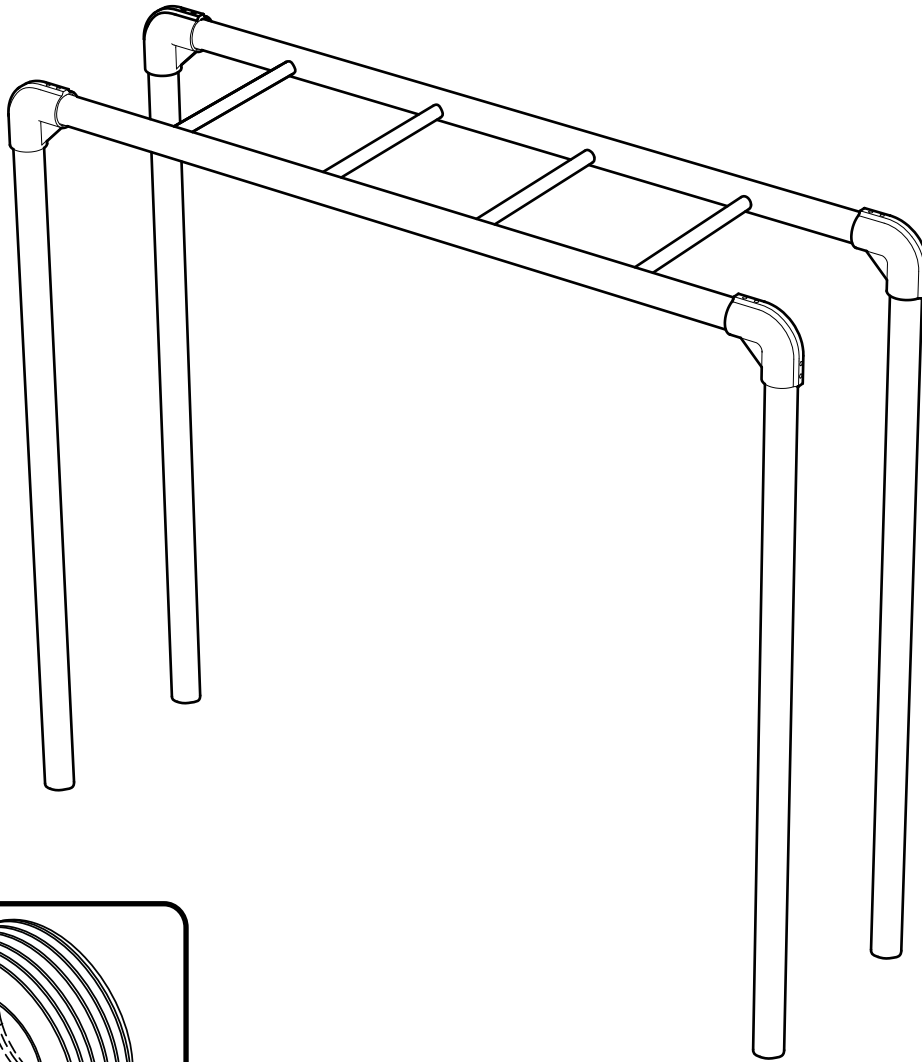

MODEL # PHJLAD

Jr. Horizontal Ladder

INSTALLATION INSTRUCTIONS

UPLAY TODAY PLAYS SYSTEMS • 800.458.5872 • www.uplaytoday.com

GROUND PLAN

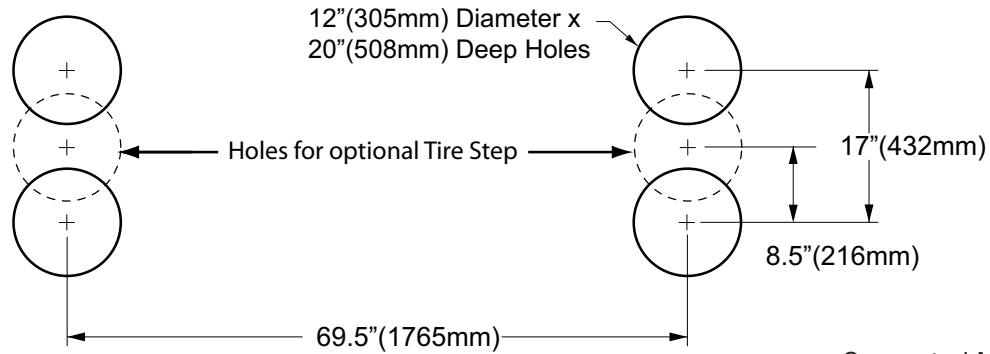

Suggested Min.
concrete rating:
3000PSI

Concrete Required: Approx. .2 Cubic Yards (.15 Cubic Meters)

Concrete Required (with optional Tire Step): Approx. .3 Cubic Yards (.25 Cubic Meters)

NOTE:

Hole depths indicated on all ground plans are measured from the finished surface. See *Footing Details*.

All Footer dimensions are based on level finished surface.

FOOTING DETAIL

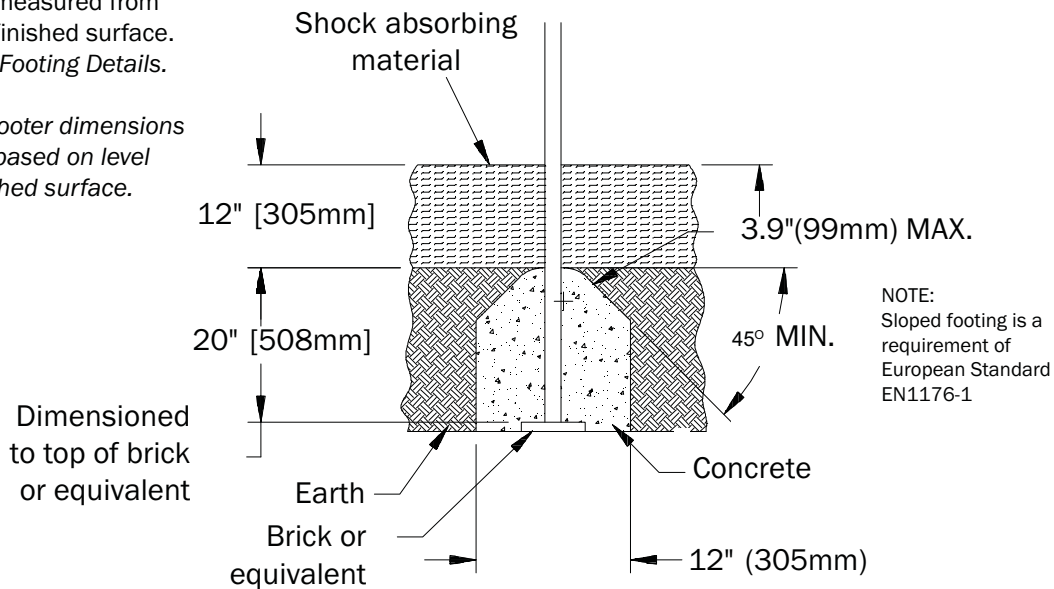

SPECIFICATONS:

Horizontal Ladder Frame and Vertical Ladder Frame are fabricated from 2-3/8" O.D. 10 gauge (.134" wall) galvanized steel tubing with 1-5/16" O.D., 14 gauge (.083" wall) steel tubing rungs. Weld assembly shall be powder coated after fabrication.

Weight: 146 lbs.

MAINTENANCE:

Periodically check hardware for tightness and tighten as necessary. Always check all parts for breakage or wear, and immediately put equipment out of service until any faulty parts found are repaired or replaced. Also check all metal parts for rust, paint loss and touch-up paint as necessary with paint. Check welded areas and verify integrity. Check periodically resilient surfacing for appropriate depth and remove extraneous materials that could cause injury, infection or disease. Maintain detailed installation, inspection, maintenance and repair records for public-use playground equipment.

INSTALLATION INSTRUCTIONS

Parts List			
Letter	Description	Quantity	Part Number
A	Horizontal Ladder	1	02-01-0007
B	Legs	4	02-01-0008
C	Elbow w/ set screws	4	55-1029

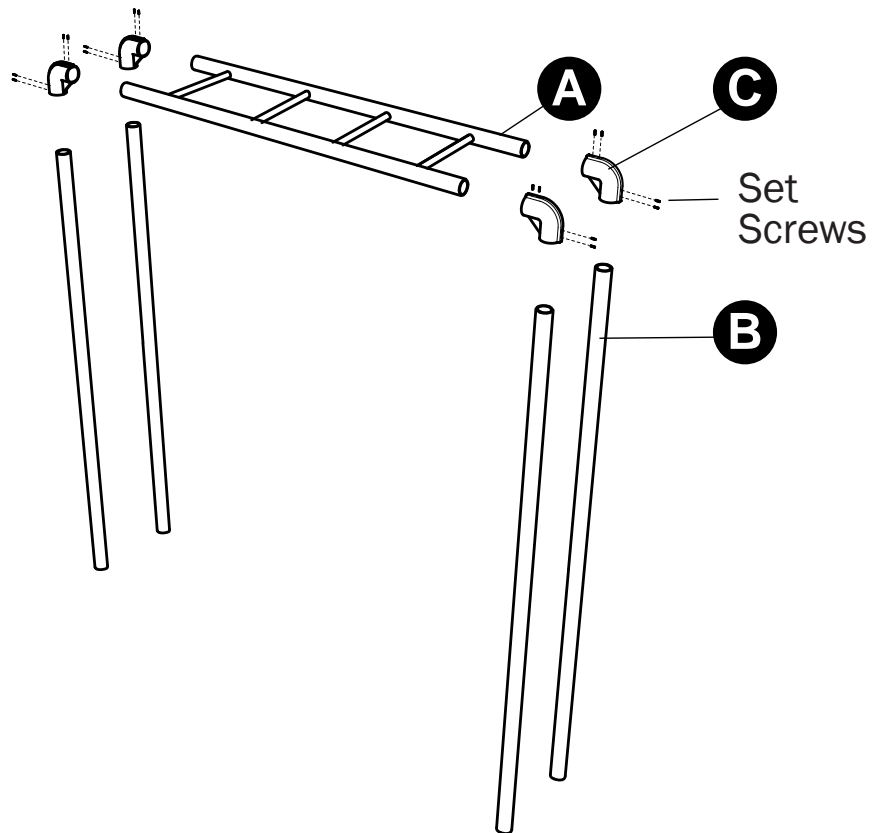

ASSEMBLY INSTRUCTIONS:

1. Dig footing holes at locations and depths indicated in Ground Plan.
2. Connect Horizontal Ladder(A) to Legs(B) using Elbow w/ Set Screws(C).
3. Secure Elbow(C) to Ladders(A) and Legs(B) using 3/8" set screws.
4. Set assembly into holes, plumb and level.

OPTIONAL TIRE STEP

Parts List			
Letter	Description	Quantity	Part Number
A	Tire	2	02-01-0023
B	Tire Mounting Post	2	02-01-0024
	Hardware Complete	1	33-12-0065
C	3/8" x 1-1/4" Hex Bolt	8	33-05-0002
D	3/8" Flat Washer	16	33-02-0002
E	3/8" Lock Washer	8	33-02-0006
F	3/8" Hex Nut	8	33-01-0002

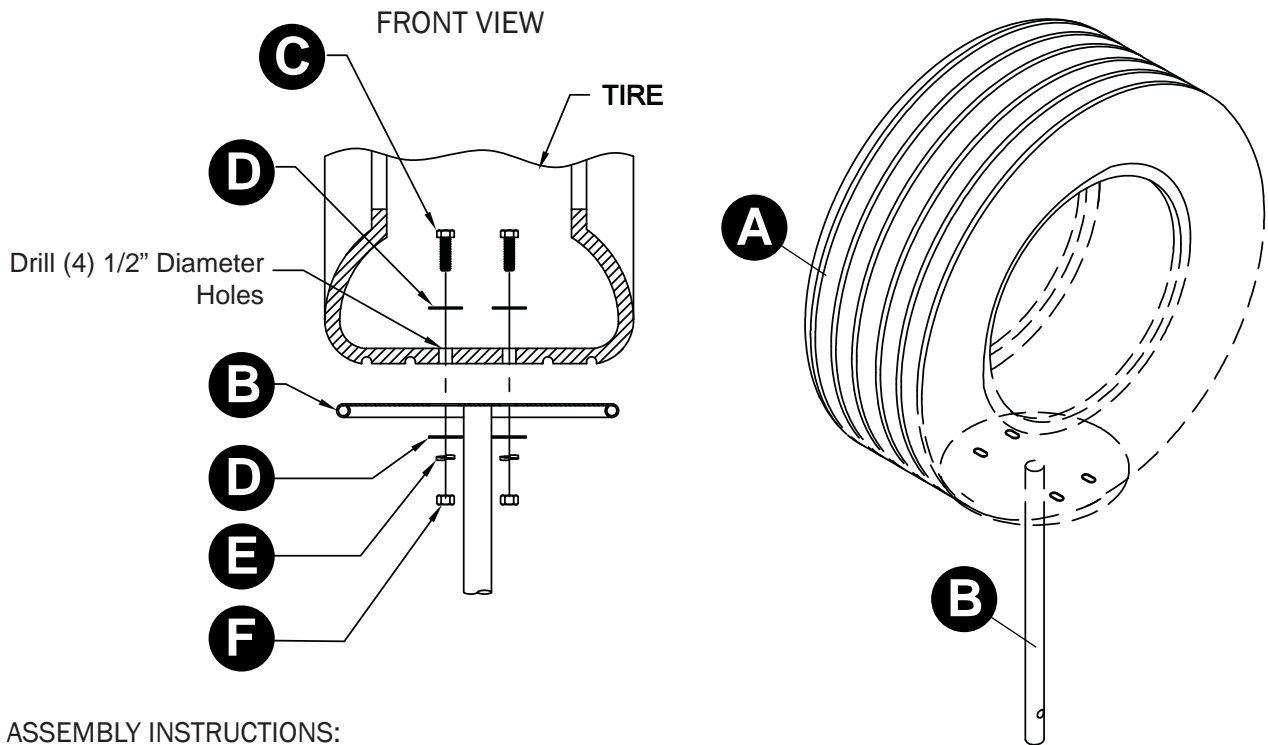

ASSEMBLY INSTRUCTIONS:

1. Dig footing holes at locations and depths indicated on ground plan.
2. Using Tire Mounting Post(B) as a guide, drill (4) 1/2" (13mm) diameter holes in Tire(A).
3. From inside of Tire(A), insert (4)Bolts(C) and (4)Flat Washers(D) into Tire(A), through slots in Tire Mounting Post(B) and secure with (4) Flat Washers(D), (4)Lock Washers(E) and (4)Hex Nuts(F).
Repeat for other Tire(A)
4. Set assembly into holes and plumb and level.
5. Pour concrete footing with within 4" to the top of the hole and taper way from the support post to allow water drainage. Allow to cure at least 48 hours before use.

NOTE: Temporary bracing may be required until concrete cures.